



## DC2 6" Dome Port for Compact Housings

Item number 6402

### Included in the Box

- DC2 dome port
- O-ring # 0119.2 (installed)
- Dome shade # 5516.05 (installed)
- Neoprene cover # 0200.1 (installed)
- Silicone lubricant # 0184.1
- Hex key # 0945.16

### Housing Compatibility

- Ikelite Underwater Housings for Sony Cyber-shot RX100 Mark I # 6116.10
- Ikelite Underwater Housings for Sony Cyber-shot RX100 Mark II # 6116.11
- Ikelite Underwater Housings for Sony Cyber-shot RX100 Mark III # 6116.12
- Ikelite Underwater Housings for Sony Cyber-shot RX100 Mark III, IV # 6116.14
- Ikelite Underwater Housings for Sony Cyber-shot RX100 Mark III, IV, V # 6116.15 / 6116.16

### Important Notices

- » **Do not use alcohol, cleaning agents, spray lubricants, Rain-X, or other solvents on the housing or lens port. Use of an incompatible chemical compound can damage the plastic or component o-rings, which may result in leaking.**
- » **DO NOT over-tighten the Dome Shade Set Screws or you may damage the shade. Over-tightening is identified by bending of the shade base away from the port around each set screw. Slowly tighten the set screws so they just make contact in the recessed areas and are snug against the port.**

## Installation and Use

### Removing the Standard Port

1. Rotate the lens port counter-clockwise to remove. We recommend using a rubber strap wrench (not included).

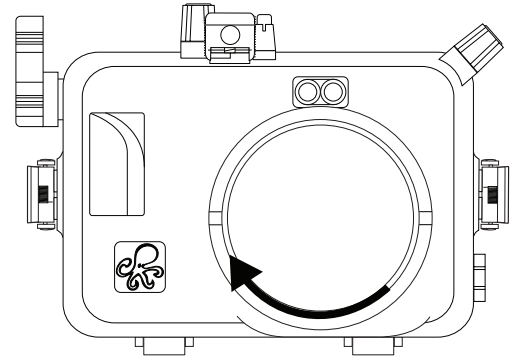

2. Store the port with o-ring in a dry, dust-free environment.

### Installing the DC2 Dome Port

1. Using the included hex key, loosen the three set screws that attach the shade to the dome port.
2. Remove the dome shade from the dome port.

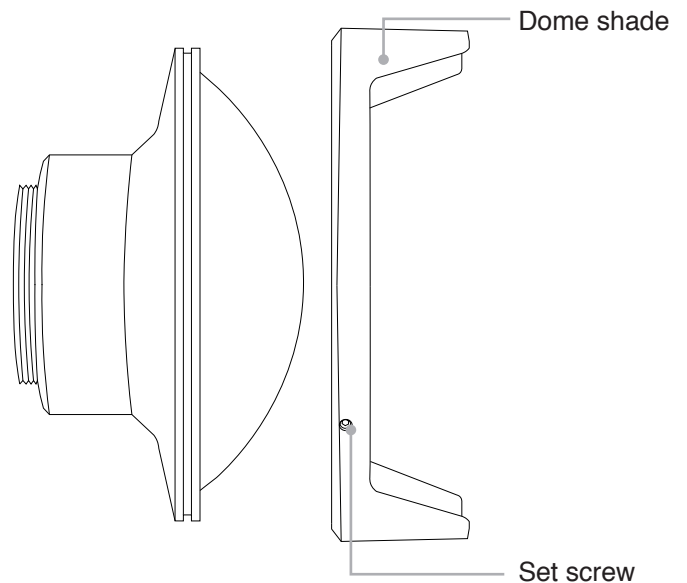

3. Check that the o-ring is in its groove on the back of the DC2 dome port.
4. Apply a very light, even coat of Ikelite silicone lubricant to the exposed surface of the o-ring.
5. Align the threads of the DC2 dome port with the threads of the opening in the front of the housing.
6. Facing the front of the housing, rotate the DC2 Dome Port clockwise and tighten until snug.

7. Align the shade extensions so that they are parallel with the top and bottom of the housing.
8. Fit the shade to the dome port and tighten the three set screws until they stop. Do not over-tighten.

## Testing the Housing

1. Assemble the housing without a camera installed.
2. Submerge the housing in fresh water for several minutes.
3. Remove the housing from water and dry the outside of the housing with a clean, lint-free cloth.
4. Look through the back of the housing for signs that water has entered the housing. Signs include fogging or water droplets.
5. We recommend making at least one dive without a camera installed to ensure waterproof operation.

## Maintenance and Storage

### Post-Dive

1. Rinse the housing with dome port installed in clean, fresh water.
2. NEVER leave your housing in the fresh water rinse tank. Collisions with other gear can cause scratches or damage to your equipment.
3. Dry the dome with a clean micro fiber lens cleaning cloth.
4. Attach the protective neoprene cover.
5. Stow the housing in a shaded place where it is protected from impact or overheating. If no shade is available, we recommend covering the housing with a towel or cloth.

### Travel and Storage

6. Clean and dry the exterior of the dome port. DO NOT use any type of alcohol or glass or surface cleaner on the dome port.
7. Attach the protective neoprene cover.
8. Store in a cool, dry place.

### Scratches

Often scratches will fill in with water and become invisible in the resulting image. Scratches are most likely to show up in your image when shooting towards the sun or a light source.

Light scratches may be buffed out using NOVUS plastic polish, available in single-use packets or bottles.

If the scratches are too deep to polish out, the dome port will need to be returned to Ikelite for replacement of the acrylic front.

## Limited Warranty

This Ikelite product is warranted against any manufacturing defects for a period of one (1) year from the original date of purchase. To obtain warranty service, the product must be returned to Ikelite postage paid. Ikelite will, at its sole discretion, repair or replace such products, and will return to customer postage paid. All other claims of any nature are not covered. Except as mentioned above, no other warranty expressed or implied applies to this Ikelite product.

## Contact Us

Ikelite Underwater Systems  
50 W 33rd St  
Indianapolis, IN 46208 USA  
(317) 923-4523  
ikelite@ikelite.com